

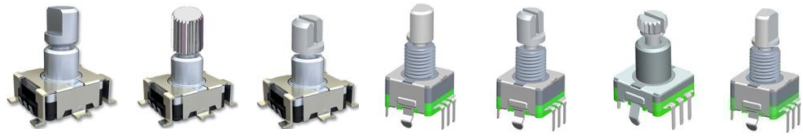

# Encoder switch

## TEEA type

### TEEA01 Series



(size : 14.2×11.7×h)

Snap-in & Surface mount Type

#### ■ Features

Incremental type  
 A push on switch with a clearclick operational feel  
 An encoder with detents and excellent operating feeling.

#### ■ Applications

Menu selection and input for Audio Visual Equipment  
 Level controls for car audio & navigation system  
 Portable audio devices,  
 Personal digital assistant.

#### ■ Main Specifications

	Encoder	Push on
Rating	10mA 5V DC	0.5mA 16V DC
Detent (pulse)/Travel	30 detent (15 pulses)	0.5mm±0.3mm
Contact Resistance	1Ω Max	100mΩ Max
Operating Force	100gf	350gf (□□: 35)
		without push (□□: 00)
Operating Life(Cycle)	15,000	20,000

#### ■ Products Line

**TEEA01** - □□□W-□  
 (Tml) (Shaft Type) (Cace Guide) (L/F)

Products No.	Terminal Type	Shaft Type	Guide Boss	Drawing No
BAWW-□	SMT	A-Shaft	With	1
BVWW-□		V-Shaft	With	2
BFWW-□		F-Shaft	With	3
AAOW-□	Snap-in	A-Shaft	With	4
AVOW-□		V-Shaft	With	5
AFOW-□		F-Shaft	With	6
ABOW-□		BKA-Shaft (B)	With	7

Tml □	
SMT	B
Snap-in	A

Cace Guide □	
With	W
With-out	0

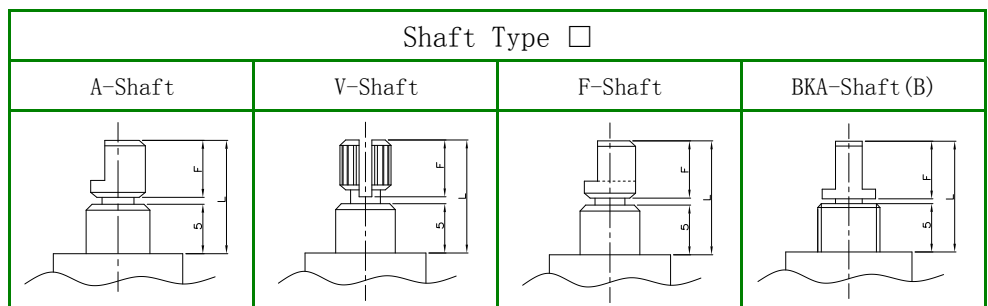

T  
E  
E

■ Dimensions

TEEA01-□□□W-□

No.	3D Style	Dimension Type (Unit : mm)	PCB pattern dimension Circuit Diagram																					
1	BAWW-□		<table border="1"> <thead> <tr> <th>P NO.</th> <th>L</th> <th>F</th> </tr> </thead> <tbody> <tr><td>BAWW-A</td><td>10.0</td><td>4.0</td></tr> <tr><td>BAWW-B</td><td>10.5</td><td>4.0</td></tr> <tr><td>BAWW-C</td><td>12.5</td><td>5.0</td></tr> <tr><td>BAWW-D</td><td>12.5</td><td>5.5</td></tr> <tr><td>BAWW-E</td><td>13.0</td><td>7.0</td></tr> <tr><td>BAWW-F</td><td>16.7</td><td>7.0</td></tr> </tbody> </table>	P NO.	L	F	BAWW-A	10.0	4.0	BAWW-B	10.5	4.0	BAWW-C	12.5	5.0	BAWW-D	12.5	5.5	BAWW-E	13.0	7.0	BAWW-F	16.7	7.0
	P NO.	L	F																					
BAWW-A	10.0	4.0																						
BAWW-B	10.5	4.0																						
BAWW-C	12.5	5.0																						
BAWW-D	12.5	5.5																						
BAWW-E	13.0	7.0																						
BAWW-F	16.7	7.0																						
			<p>Circuit Diagram</p>																					
2	BVWW-□		<table border="1"> <thead> <tr> <th>P NO.</th> <th>L</th> <th>F</th> </tr> </thead> <tbody> <tr><td>BVWW-A</td><td>9.5</td><td>3.5</td></tr> <tr><td>BVWW-B</td><td>11.0</td><td>3.5</td></tr> <tr><td>BVWW-C</td><td>11.5</td><td>5.0</td></tr> <tr><td>BVWW-D</td><td>12.5</td><td>5.0</td></tr> <tr><td>BVWW-E</td><td>13.0</td><td>5.0</td></tr> <tr><td>BVWW-F</td><td>15.3</td><td>7.8</td></tr> </tbody> </table>	P NO.	L	F	BVWW-A	9.5	3.5	BVWW-B	11.0	3.5	BVWW-C	11.5	5.0	BVWW-D	12.5	5.0	BVWW-E	13.0	5.0	BVWW-F	15.3	7.8
	P NO.	L	F																					
BVWW-A	9.5	3.5																						
BVWW-B	11.0	3.5																						
BVWW-C	11.5	5.0																						
BVWW-D	12.5	5.0																						
BVWW-E	13.0	5.0																						
BVWW-F	15.3	7.8																						
			<p>Circuit Diagram</p>																					
3	BFWW-□		<table border="1"> <thead> <tr> <th>P NO.</th> <th>L</th> <th>F</th> </tr> </thead> <tbody> <tr><td>BFWW-A</td><td>10.0</td><td>4.0</td></tr> <tr><td>BFWW-B</td><td>10.5</td><td>4.0</td></tr> <tr><td>BFWW-C</td><td>12.0</td><td>5.0</td></tr> <tr><td>BFWW-D</td><td>14.0</td><td>6.0</td></tr> <tr><td>BFWW-E</td><td>14.5</td><td>8.0</td></tr> <tr><td>BFWW-F</td><td>16.5</td><td>8.0</td></tr> </tbody> </table>	P NO.	L	F	BFWW-A	10.0	4.0	BFWW-B	10.5	4.0	BFWW-C	12.0	5.0	BFWW-D	14.0	6.0	BFWW-E	14.5	8.0	BFWW-F	16.5	8.0
	P NO.	L	F																					
BFWW-A	10.0	4.0																						
BFWW-B	10.5	4.0																						
BFWW-C	12.0	5.0																						
BFWW-D	14.0	6.0																						
BFWW-E	14.5	8.0																						
BFWW-F	16.5	8.0																						
			<p>Circuit Diagram</p>																					

T E E



■ Dimensions

TEEA01-□□□W-□

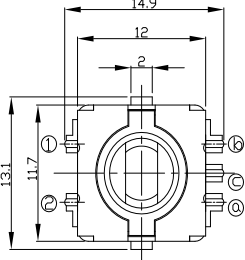
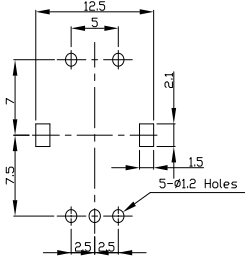
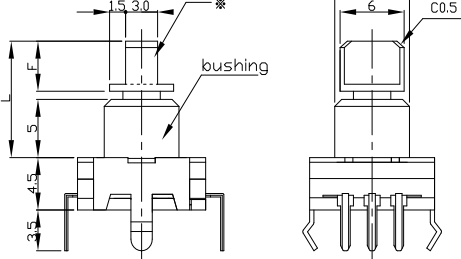
No.	3D Style	Dimension Type (Unit : mm)	PCB pattern dimension Circuit Diagram																					
7	ABOW-□		<table border="1" data-bbox="906 297 1064 517"> <thead> <tr> <th>P NO.</th> <th>L</th> <th>F</th> </tr> </thead> <tbody> <tr> <td>ABOW-A</td> <td>10.0</td> <td>3.5</td> </tr> <tr> <td>ABOW-B</td> <td>10.5</td> <td>4.0</td> </tr> <tr> <td>ABOW-C</td> <td>11.0</td> <td>5.0</td> </tr> <tr> <td>ABOW-D</td> <td>13.0</td> <td>6.0</td> </tr> <tr> <td>ABOW-E</td> <td>15.0</td> <td>7.0</td> </tr> <tr> <td>ABOW-F</td> <td>15.0</td> <td>8.0</td> </tr> </tbody> </table> 	P NO.	L	F	ABOW-A	10.0	3.5	ABOW-B	10.5	4.0	ABOW-C	11.0	5.0	ABOW-D	13.0	6.0	ABOW-E	15.0	7.0	ABOW-F	15.0	8.0
	P NO.	L	F																					
ABOW-A	10.0	3.5																						
ABOW-B	10.5	4.0																						
ABOW-C	11.0	5.0																						
ABOW-D	13.0	6.0																						
ABOW-E	15.0	7.0																						
ABOW-F	15.0	8.0																						
		<p data-bbox="1177 618 1283 640">Circuit Diagram</p> 